

## Virtual Machine® Graphic Machine Tool Simulation

Virtual Machine seamlessly unites ICAM's advanced NC post-processing solution, CAM-POST, with a comprehensive graphical machine tool simulator. Virtual Machine enables NC programmers to graphically simulate and test programs, easily & automatically, against collision and over-travel during post-processing. Virtual Machine allows NC programmers to avoid and correct possible programming errors that may have resulted in costly machine tool collisions and defective parts.

### Graphic NC Post-Processing

Graphic NC post-processing is a real-time graphic simulation of the block-to-block machine tool motion instructions generated by the NC post-processor. Graphic NC post-processing technology uses a single, complete database to simultaneously execute the NC post-processor & graphic engine. Since the two technologies are fully integrated, Virtual Machine provides real-time feedback to the post-processor; thereby, allowing manufacturing issues such as machine collisions & over-travel to be automatically detected and repaired.

### Supports Mill / Turn Machining Centers

Virtual Machine features all the necessary software components to fully support Mill / Turn centers including the ability to synchronize dual turret merging lathes, the capacity to accurately simulate constant surface speed as well as the provision to define and model lathe tool inserts and generic 3D tool holders. Virtual Machine also provides the environment to define a rotary axis as either a spindle or a lathe tool turret.

### Material Removal / Verification

Virtual Machine supports Material Removal / Verification capabilities for in-process stock collision and gouge detection within a completely simulated machining environment. Material Removal / Verification, available for 3-axis & 5-axis machining applications, allows NC programmers to compare the processed stock model to the original CAD / CAM design. Virtual Machine computes in-process stock geometry to identify, list and display surface gouges, excess material, inaccessible areas and rapid-motion collisions at any time during the post-processing and verification phase.

### SmartPATH™ for Automatic Toolpath Optimization

SmartPATH™ is unique software designed to automatically optimize rapid positioning toolpath motions generated by CAD/CAM systems. This software provides savings both in CNC run-time positioning & in CAD/CAM toolpath preparation.

Rapid positioning motions generated by CAD/CAM software do not take into account machine tool kinematics, workpiece setup and travel limitations and therefore, place the burden of responsibility for safe and efficient positioning onto the NC programmer. Rapid positioning tool-paths often must be redeveloped and carefully verified by the NC programmer when migrating programs from one CNC machine to another.

SmartPATH™ identifies inefficient and unsafe positioning motions and automatically replaces them with minimized collision free safe motions based on the actual machine tool kinematics, physical travel limits, axes positioning rates and the dynamically changing state of the in-process stock.

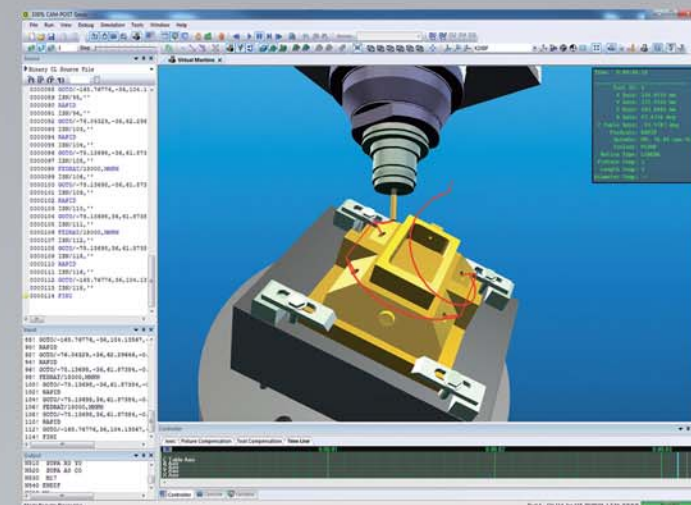
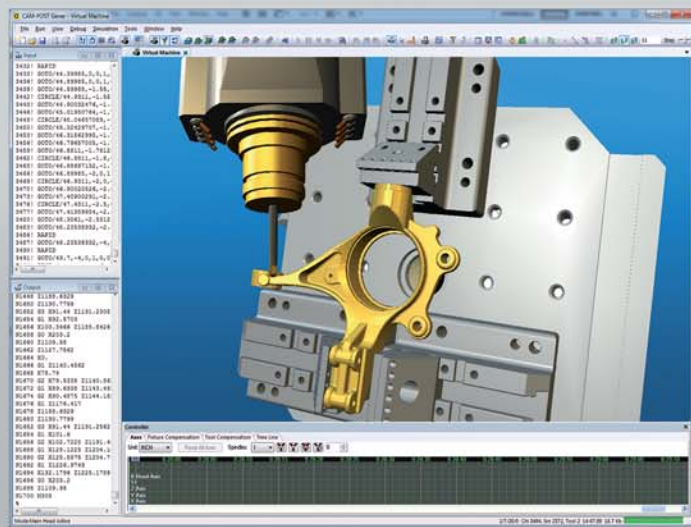

GET  
INTEGRATED PSE

## Feature / Benefit Highlights

### Unique Timeline Control

Virtual Machine offers a unique Timeline Control that provides bi-directional review and playback of NC programs at any moment within the machining cycle. This unique function allows programmers to visualize and test NC post-processor for maximum output optimization.

### Efficient Post-Processor and Machine Model Development

The machine tool and controller data for both Virtual Machine and CAM-POST are stored and managed in the same database. This eliminates the error-prone and time-consuming alternative of entering the same data twice when using a non-integrated solution.

### Cost-Effective NC Tape Proofing

Virtual Machine detects and corrects collisions between machine components, in real-time, during post-processing. As a result, Virtual Machine reduces scrap materials and minimizes tool replacements while increasing machine utilization and improving part quality.

### Leverage Existing Technology

Virtual Machine works with existing NC post-processors generated using CAM-POST. Subsequently, existing post-processors can be tested for errors and updated automatically within a single user interface.

### Machine Tool Motion Inspection

Virtual Machine may be synchronized with CAM-POST's interface at any collision or over-travel error; thereby, allowing the user to graphically examine the part program and tape output precisely where the problem occurred. With this powerful tool, errors that could have damaged the part, tool and fixture can be eliminated.

### Virtual Machine Provides a Training Environment

Virtual Machine's unique software environment provides users with a comprehensive understanding of their machine tool. With its intuitive user interface, Virtual Machine may be used as an efficient, cost-effective training tool that allows NC programmers and machine operators to explore advanced features of their machine tools and test NC programs, off-line, in a virtual environment.

### Technical Highlights

- Mill / Turn Simulation with Material Removal
- Shows the machine status at any point of the simulation process
- "Nearness concept" function allows collision detection and reporting to account for safety margins uniquely defined in each machine component
- Macro functions are available to customize the behavior of complex models
- New tool definition and functions to support probe simulation
- Windows XP, Vista, 7 and 8 compliant installation & operation

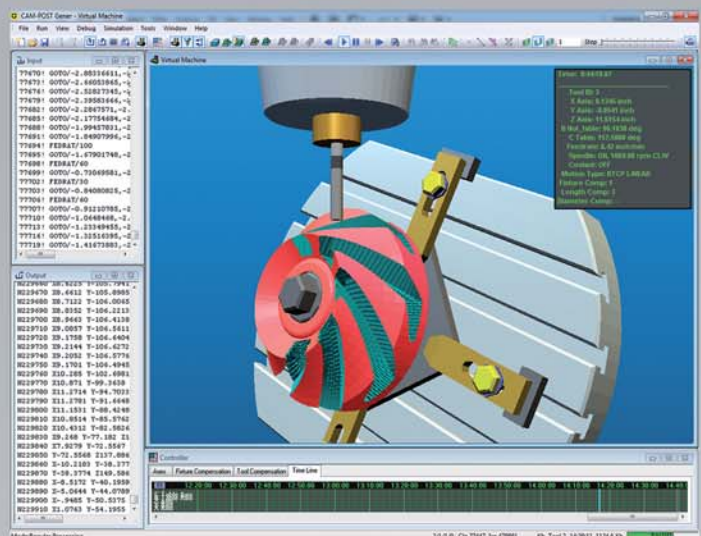
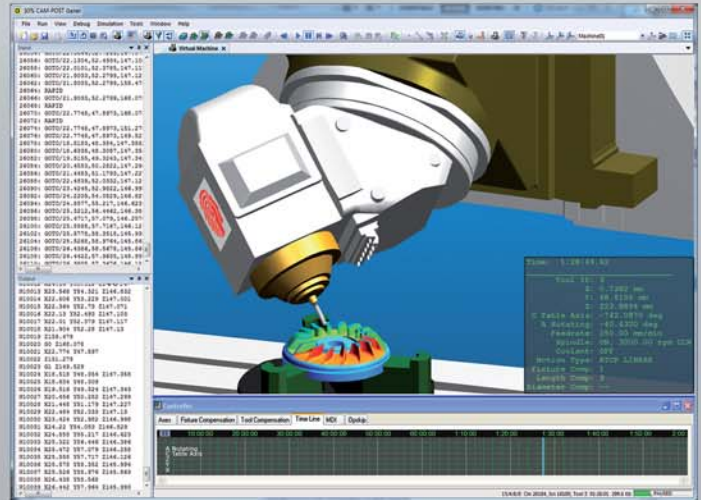

# ICAM

